

Installation Guide

X-One / X-One TCi EVO



Please carefully read this pre-installation guide before attempting to book or install your Conti X-One Espresso Machine. This simple guide is designed to give you all the information you'll need to prepare for your machines arrival. Once you've completed your pre-installation checks, please sign and return this form to your Conti distributor.

Machine Specifications

Front

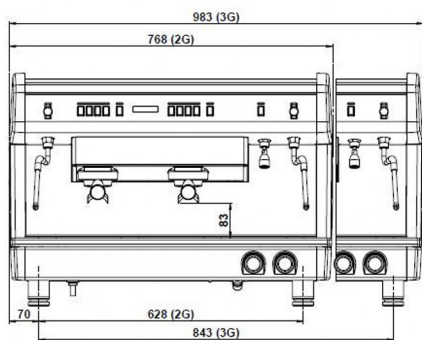

Side

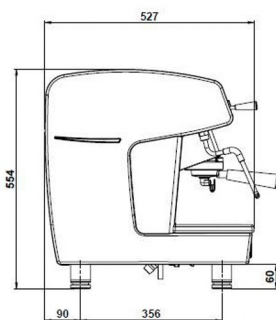

Arial

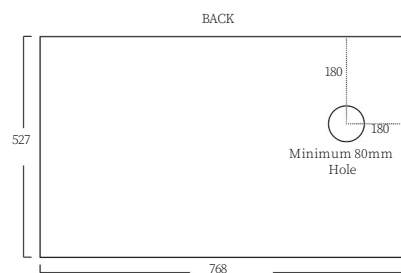

Disclaimer: This is a suggested hole location, with approximate dimensions.

Counter Top Drilling

When preparing to drill your counter top, the key point to consider is that the waste hose needs a continuous drop. You will need a minimum of an 80mm hole, all of the utility cables and hoses are flexible therefore a central position provides best access and minimises drilling.

Model	Groups	Steam Boiler Size	Total Electrical Load	Recommended Breaker	Drained Weight	Operational Weight
X-One Evo	2	13L	3800W	20A	58Kg	71Kg
X-One Evo	3	20L	6300W	32A	74Kg	93Kg
X-One TCI Evo	2	13L	4500W	20A	60Kg	73Kg
X-One TCI Evo	3	20L	6300W	32A	76Kg	95Kg

Delivery

Prior to delivery, your machine is wet tested by our in house technician in the UK, under going a multipoint preparation. This is to ensure that your machine is in perfect working condition prior to installation. This means the machine will be at operational weight. Please consider this when making provisions to move the machine.

Upon receipt of the machine, please inspect the package carefully for any damage. Please report any damage to your supplier within 24 hours of delivery. We don't recommend removing anything from the shipping crate unless instructed to do so.

Suggested Work Station Layout

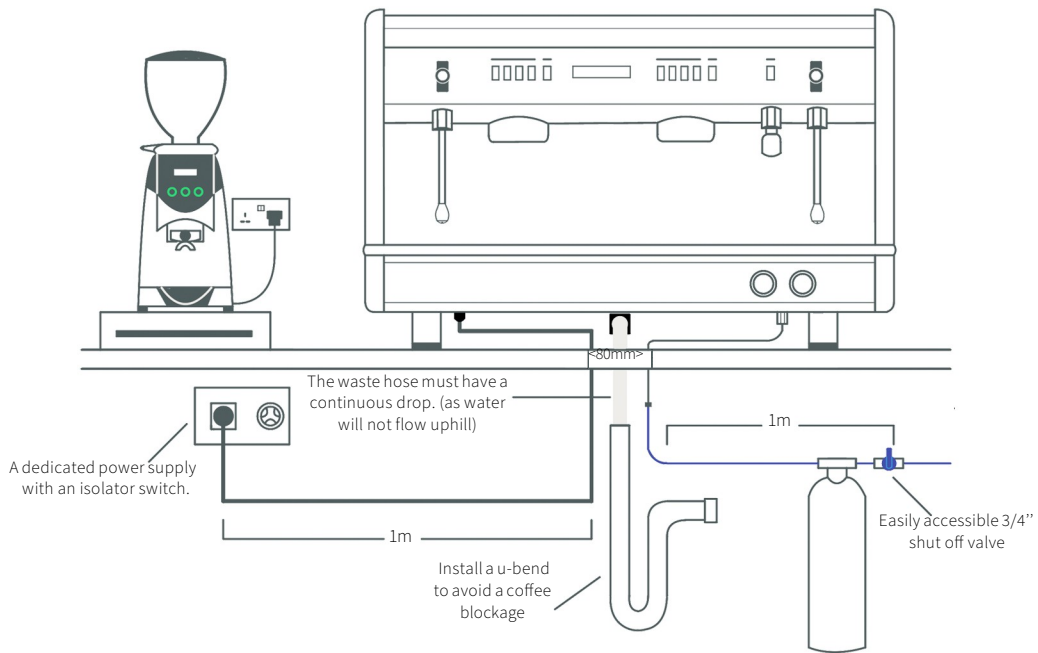

Pre-installation Check list

- A dedicated electrical supply within 1 meter of the final machine location is installed. (for power requirements refer to the table on page 1)
- A dedicated cold water supply terminating within 1metre of the machine location, fitted with 3/4" washing machine shut off valve is available.
- A straight upstand and U-bend is fitted directly under the machine, under the counter. If plumbed waste isn't available, please make sure a suitable container is available to collect waste water.
- Both the electrical and plumbing services are tested and working.
- There is space under the counter clear for access to water, waste and power supply. (remove utilities) Space is also required for a water treatment unit. approx. 525mm H x 175mm W.
- There is a 13A pin socket for the grinder installed above the counter.
- A minimum of 80mm hole is drilled into the counter to accept the water, power and waste feeds. (Installation engineers can only drill soft wooden surfaces by prior arrangement only)
- Someone will be on site to assist with lifting equipment.
- The worktop is capable of supporting 150kg, minimum.
- There is space for a work area outlined in the diagram above.
- Coffee, Cups and milk will be on site for callibration.

I understand that by signing, all of the points detailed above are in place and ready. Should any of the above not be fulfilled I understand that this may result in additional costs or an aborted installation charge of £130.00+vat.
 If you are unsure of anything, please contact us on the number below.
 (Site ready photos are encouraged)

Name:

Signature:

Date: